

TEXAS SOLAR POWER COMPANY

1703 West Koenig Lane, Austin, Texas 78756
 Phone: (512) 459-9494 Fax: (512) 451-5934
 Toll Free: (866) 459-9494
 Web: txspc.com
 Email: info@txspc.com

Texas Solar Power Company (TXSPC) specializes in the design and installation of renewable energy systems. We provide an alternative, sustainable power source for residential, commercial and government clients. TXSPC offers outstanding service using high quality products delivered at competitive prices.



Photovoltaic (PV) is clean energy from the fuel source that belongs to all of us - the sun.



We carry everything you need for your renewable energy project. TXSPC is an authorized dealer of SolarWorld, Sharp Solar, and Kyocera modules as well as SMA and Fronius products. As technology in the renewable energy industry is dynamic, we are constantly evaluating new products and manufacturers to offer the best package to the environmentally and energy conscious public.



Our services are available around the world—wherever there is a need for photovoltaics.



Sales • Design • Installation

Owners Craig Overmiller, Architect, and Joe Garcia have been in the renewable energy field since 1995 helping home and business owners towards energy independence. The TXSPC team of designers and installers are committed to professional presentation and quality work.

Residential • Commercial

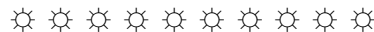

Texas Solar Power Company headquarters is a working example of integrating both a wind turbine as well as a hybrid grid-tie solar system.

- The 1st floor is an SMA Sunny Island grid-tie system with back-up batteries.
- The 3rd floor is an Outback stand-alone system.
- We also have two Air 403 wind generators on the roof for additional power.



Owner is
NABCEP Certified



At Texas Solar Power Company, YOU have the POWER.



How much Solar Power do I need?

Step #1: First things first, CONSERVATION.

Before you begin to "size" a solar system for your existing home, Texas Solar Power Company recommends that you implement several energy management and conservation techniques in order to reduce your overall need for energy:

- Change all incandescent and halogen light sources to compact fluorescent lighting (CFLs). Home Depot is a great source for these indoor or outdoor lamps and fixtures. Most compact fluorescent lamps will fit into existing lamp sockets. This will result in double savings – fewer watts used to light a space AND less A/C used to cool down the air around those little heat lamps!
- Wherever possible, add additional insulation to your attic walls and floors. Use pipe insulation on heated water pipes. Insulate your hot water heater.
- Programmable thermostats can make a significant difference if you routinely leave your house for extended periods. Some electric companies offer these at reduced prices.
- Add shading devices and/or solar screens to your east, south, and west-facing windows. However, during winter months, you may want to take off the south-facing screens in order to *gain* solar heat.
- If you have old appliances, consider upgrading. Today's appliances are *much* more energy efficient than those made as few as 5 years ago. We highly recommend that you purchase only Energy Star rated appliances and air conditioning equipment.
- Use natural gas or propane appliances where possible for cooking, central heating, water heating, and for your clothes dryer. Better yet, dry your clothes via solar (clothesline)!

Step #2: What do you want to do with the power?

If you are already served by a power company, it is considerably cheaper to purchase a "grid-tie" system. If you want to be totally independent of your energy company and/or you need electricity in a location that is not yet served by your energy company and it would be very expensive to connect, you will want to consider a "Battery Stand-Alone" system. A "Battery Back-up" system is a combination of the two systems, where batteries are used as a back up for a power outage in an emergency situation.

- ❑ **Grid-tie:** You generate power during the day (while the sun is out) so if you're producing more than you're using, your meter will run backwards. Your energy company supplies the power you use at night, so your meter will run forwards. This push-pull will "net" at the end of the month with a balance either in the customer's favor or in the electric company's favor. In this dynamic, the power company acts as a huge energy storage device/battery.
- ❑ **Battery Stand-Alone:** Along with the solar panels and support system, you will need to purchase batteries. Your solar panels charge the batteries and you then draw energy needed for your house from the batteries. You would need to determine all energy needs and make sure your system is large enough to acquire and store enough energy.
- ❑ **Battery Back-Up:** This is a hybrid system that is useful when power goes out. You can pre-determine which appliances should never be without energy, and then store that needed power. For example, you might have emergency back up for your refrigerator, computer, and 4 lights.

Step #3: Consider how much power you actually use.

Realistically, you will probably look to *supplement* your power needs via solar ("grid-tie" as described above) rather than use a Battery Stand-Alone system. If you want more information about battery back up and true system sizing, please let us know – we have an overview you can use to determine your full power needs. However, if you simply want an understanding of how much electricity you use and how much a solar system will produce, follow the steps below.

One way to look at the math:

1. Solar systems are generally sized in 1 kW – 6 kW (and larger) systems. A typical size is 3 kW.
2. 3 kW, or 3 kilowatts = 3,000 watts
3. A 3 kW system will generate around 3,000 watts per hour
4. Multiply the per hour generation by 5.4 which is an average number of sun hours in a day ($3,000 \times 5.4 = 16,200$)
5. Multiply the new total by the average number of days in a month ($16,200 \times 30.5 = 487,620$)
6. Multiply the new total by .77. This is the “derating” factor, or the amount of energy lost when DC current is turned into AC current. ($487,620 \times .77 = 375,467$)
7. So, a 3 kW system will generate about 375,467 watt-hours per month, or about 375 kWh.
8. Now compare this number with the kWh usage noted in your electric bill. How many kWh do you use in a typical month? Twice this amount? Then you would save roughly $\frac{1}{2}$ your electric bill if you installed a 3 kW system.
9. Consider how much money you save per month to figure out how long it will take to pay off your system.

Another way to look at the math – in reverse:

1. Take a look at your electric bill to find the number of kilowatt-hours (kWh) you use in a month. Remember that your summer bills may be higher than those in winter (or vice versa) so determine an average.
2. Multiply your kWh by 1000 to get a number in terms of watts.
3. Divide this number by the average number of days in a month: 30.5
4. Divide the resulting number by the average number of good hours of sunlight per day: 5.4
5. Now divide the resulting number by the output of the solar module you intend to use. A standard is 175 watts.
6. The resulting number is about how many modules you would need to meet all your power needs.

Step #4: Information to keep in mind when considering a solar system.

- A. Up to 30% of the final cost of installation can be taken as a federal tax credit. Previous versions of this credit had a cap of \$2,000; there is no longer a cap.
- B. The most productive system is located on a South- or West-facing roof (or area) that is shade-free from 9 am – 3 pm every day of the year.
- C. Generally speaking, you will need ~ 1 square foot of space for every 10 watts. So a 3 kW system would take ~ 300 square feet; a 4 kW system would take ~ 400 square feet.
- D. Solar panels can weather routine hailstorms. If a hailstorm breaks car windshields, it can break you solar panels. Storms of this intensity are rare, but do happen. Once your system is on your house, it is covered by your homeowner’s insurance.
- E. You do not need to size a system to meet all your energy needs. You will remain a customer of your electric company, so you can use more (or less) power as needed.
- F. When considering “payback” time, think about the price of electricity per kWh. Has it increased in the past? Will it increase in the future? By how much? We do not know the answer either, but the question should be factored in to your decision-making.
- G. All energy providers are obligated to allow “net-metering” which means that the electric meter must be able to run backwards (i.e. when you are generating electricity). However, they are not obligated to pay you a set \$ amount, or anything at all, if you generate more energy than you use in a month. Check with your energy provider to find out their particular “Tariff Agreement”.
- H. Be sure to check with your Homeowners’ Association before committing to a solar PV installation. For some odd reason that we simply cannot imagine, some are opposed to the “look” of solar.



1703 W. Koenig Ln. Austin, TX 78756
 Phone: 512-459-9494 Fax 512-451-5341
 Website: txspc.com
 Email: info@txspc.com

SAMPLE PROPOSAL

Proposal No.
 Date: July 20, 2008

Sales Person: VG
 Terms: 60 Days

To: Bryan Utility Customer

Project: Grid tie PV System
 3,150 DC Watts/ 3,008 AC Watts
 Based on Inverter Efficiency (95.5%)
 Turn-key Installation

Item No.	Quantity	Description	Unit Price	Amount
1	18	Solar World, Suntech, or Kyocera 175W Solar Modules	\$780.00	\$ 14,040.00
2	1	SMA SB 3,000US Watt Inverter 95.5%	\$2,000.00	\$ 2,000.00
3	18	Array Frames	\$30.00	\$ 540.00
4	2	DC/AC Disconnect	\$115.00	\$ 230.00
5	1	20 amp Two pole Breaker	\$27.50	\$ 27.50
6	1	Combiner Box	\$65.00	\$ 65.00
7	1	Wire, Conduit and Connectors	\$500.00	\$ 500.00
8				\$ -
9				\$ -
10				\$ -
11				\$ -
12				\$ -
13				\$ -
14				\$ -
15				\$ -
16				\$ -

Terms Subject to Working Contract
 If you have any questions concerning this proposal, call:
 Craig Overmiller, Secretary/Treasurer 512-459-9494

Subtotal	\$	17,402.50
Sales Tax	0.0825	\$ 1,435.71
Labor		\$ 3,100.00
Total	\$	21,938.21
Bryan Utility Rebate	\$	12,000.00
Out of pocket	\$	9,938.21
*30% Federal Income Tax Credit	\$	2,981.46
Potential Final Total	\$	6,956.74

Pricing and availability of specific products are subject to change due to dynamic market conditions.

*Texas Solar Power Company recommends that you consult with your tax professional before investing in solar energy to determine how incentives relate to you.

Example of solar module TXSPC integrates into PV system design. Specific products dependent on market availability.



Length 63.39 in (1610 mm)
Width 31.89 in (810 mm)
Height 1.34 in (34 mm)
Frame Aluminium
Weight 33 lbs (15 kg)

Sunmodule SW 155/165/175 mono

The Sunmodule Plus heralds an innovative new module concept from SolarWorld AG. The fully automated production process at the SolarWorld factories creates a quality of module that is consistently high, which in turn will ensure high yields for the long term.

The module frame and the glass it surrounds are firmly attached to each other by silicone that is applied with continuous precision. This guarantees exceptional rigidity for the entire module and stops any possible loosening of the frame as a result of strong outward forces in cases such as sliding of heavy snow. Tests carried out in accordance with IEC 61215, applying loads up to 5.4 kN/m², confirm that the module can withstand heavy accumulations of snow and ice.

The patented, flat and compact junction box provides perfect protection against corrosion, as well as a capacity to rapidly rid itself of any excess heat providing high temperature handling. The junction box is reliably connected by a solid, welded bond to guarantee lasting functionality. In addition, high-quality, robust cables with factory-equipped connectors are used. The ability to recycle the modules and a 25-year performance warranty are the finishing touches to this top-quality concept.



Sunmodule

SW 155/165/175 mono

Performance under standard test conditions

		SW 155	SW 165	SW 175
Maximum power	P_{max}	155 Wp	165 Wp	175 Wp
Open circuit voltage	V_{oc}	43.6 V	44.0 V	44.4 V
Maximum power point voltage	V_{mpp}	34.8 V	35.3 V	35.8 V
Short circuit current	I_{sc}	4.90 A	5.10 A	5.30 A
Maximum power point current	I_{mpp}	4.46 A	4.68 A	4.89 A

Performance at 800 W/m², NOCT, AM 1.5

		SW 155	SW 165	SW 175
Maximum power	P_{max}	110.8 Wp	118.0 Wp	125.1 Wp
Open circuit voltage	V_{oc}	39.4 V	39.8 V	40.2 V
Maximum power point voltage	V_{mpp}	31.2 V	31.6 V	32.1 V
Short circuit current	I_{sc}	4.05 A	4.22 A	4.38 A
Maximum power point current	I_{mpp}	3.55 A	3.73 A	3.90 A

Minor reduction in efficiency under partial load conditions at 25°C: at 200 W/m², 95% (+/- 3%) of the STC efficiency (1000 W/m²) is achieved.

Component materials

Cells per module	72
Cell type	monocrystalline silicon
Cell dimensions	125 x 125 mm ²

System integration parameters

Maximum system voltage SC II	1,000 V _{DC}
Maximum system voltage USA NEC	600 V _{DC}
Maximum series fuse rating	15 A

Thermal characteristics

NOCT	46°C
TC I_{sc}	0.036 %/K
TC V_{oc}	-0.33 %/K

Additional data

Power tolerance	+/- 3 %
Junction box	IP 65
Connector	MC type 4

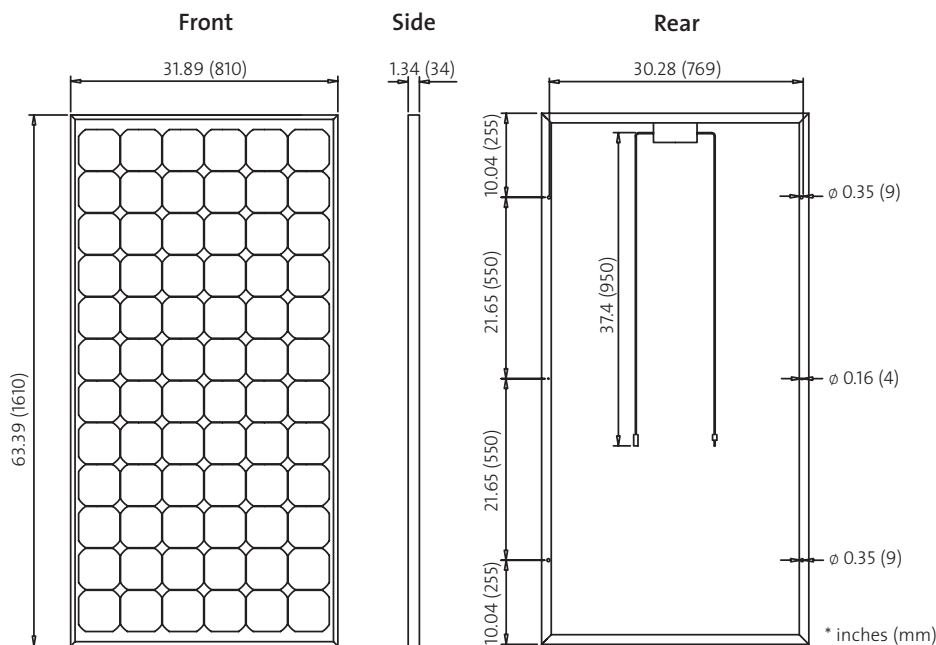

Construction

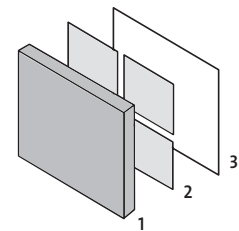

- 1] Front: tempered glass
- 2] crystalline solar cells embedded in EVA (ethylene-vinyl-acetate)
- 3] Rear: Tedlar

Modules certified in accordance with:



SolarWorld AG reserves the right to make specification changes without notice.
This data sheet complies with the requirements of EN 50380.

SunTech Power

STP 175/170/165/160S-24/Ab-1



Performance

- High power tolerance (+/- 3 %)
- 72 cell monocrystalline
- Nominal 24 V

Built for long service life

- Cells embedded in EVA (ethylene vinyl acetate)
- Transmissive low-iron, tempered glass on the front
- Weather and waterproof film back
- High strength frame

Simple installation

- Polarized Multi-Contact DC-rated waterproof connectors
- Clear anodized aluminum frame with pre-drilled holes

High quality standards

- Optical, mechanical and electrical module testing during and post-production
- Automated production line ensures consistently high level of product quality

Warranties and certifications

- 2 year product warranty
- 12 year warranty on 90 % of the minimum output
- 25 year warranty on 80 % of the minimum output
- UL 1703

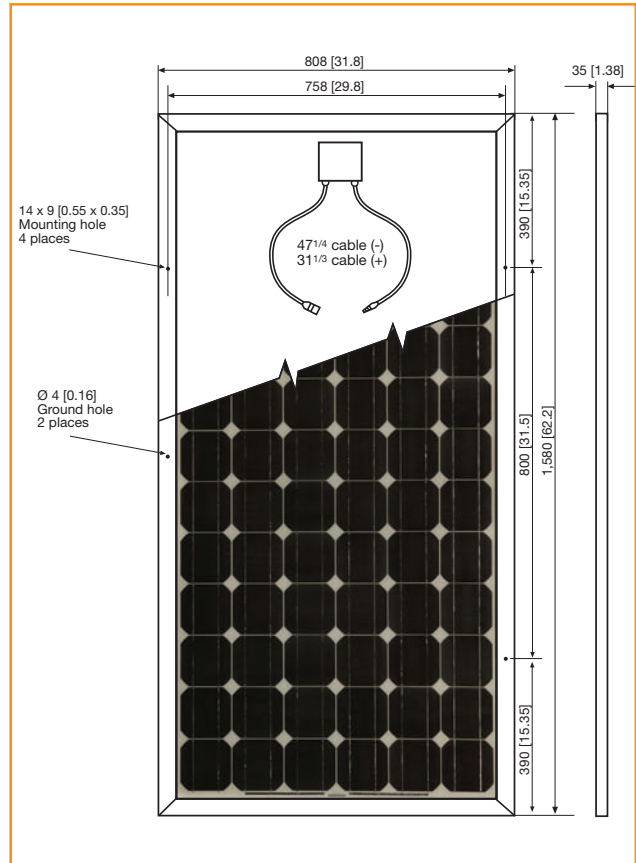

	STP 175S-24/Ab-1	STP 170S-24/Ab-1	STP 165S-24/Ab-1	STP 160S-24/Ab-1
Maximum output (Pmax)	175 W	170 W	165 W	160 W
Tolerance of the power (+/-)	3 %	3 %	3 %	3 %
Maximum power voltage (Vmp)	35.2 V	35.2 V	34.8 V	34.4 V
Maximum power current (Imp)	4.95 A	4.83 A	4.74 A	4.65 A
Open-circuit voltage (Voc)	44.2 V	43.8 V	43.6 V	43.2 V
Short-circuit current (Isc)	5.20 A	5.14 A	5.04 A	5.00 A
Temperature coefficient (Pmax)	-0.5 %/°C	-0.5 %/°C	-0.5 %/°C	-0.5 %/°C
Temperature coefficient (Voc)	-0.155 V/°C	-0.155 V/°C	-0.155 V/°C	-0.155 V/°C
Temperature coefficient (Isc)	3 mA/°C	3 mA/°C	3 mA/°C	3 mA/°C
Maximum series fuse rating	8 A	8 A	8 A	8 A
Maximum system voltage	600 V	600 V	600 V	600 V

Applies to all modules:

Module dimensions (L x W x H)	62.2 x 31.8 x 1.38 inch (1,580 x 808 x 35 mm)
Weight	34.2 lbs/15.5 kg

Available from:

- > Certified to the new UL1741/IEEE 1547
- > Improved CEC efficiency
- > Integrated load-break rated DC disconnect switch
- > Integrated fused series string combiner
- > Sealed electronics enclosure & Opticool
- > Comprehensive SMA communications and data collection options
- > 5 year standard warranty with optional 10 year plan
- > Ideal for residential or light commercial applications
- > Rugged cast aluminum outdoor rated enclosure

Example of inverter TXSPC integrates into PV system design. Specific products dependent on market availability.



Sunny Boy 3000 / 4000

The best in their class

SMA is proud to introduce our new line of inverters updated with our latest technology and designed specifically to meet the new IEEE 1547 requirements. Compact design makes them ideal for residential use and the integrated DC disconnect makes installation more cost effective. They are field-configurable for positive ground systems making them more versatile than ever. Increased efficiency means better performance and shorter payback periods. With over 500,000 fielded units, Sunny Boy has become the benchmark for PV inverter performance and reliability throughout the world.



Technical Data

Sunny Boy 3000 / 4000

	SB 3000US	SB 4000US
Input Data (DC)		
Recommended Array Input Power (DC @ STC)	3600 W	4800 W
Max. DC Voltage	500 V	600 V
Peak Power Tracking Voltage	180 - 400 V @ 208 VAC 200 - 400 V @ 240 VAC	220 - 480 V @ 208 VAC 250 - 480 V @ 240 VAC
DC Max. Input Current	17 A	18 A
DC Voltage Ripple	< 5%	< 5%
Number of Fused String Inputs	4	4
PV Start Voltage (adjustable)	228 V	285 V
Output Data (AC)		
AC Nominal Power	3000 W	3500 W @ 208 V / 4000 W @ 240 V
AC Maximum Output Power	3000 W	4000 W
AC Maximum Output Current	15 A	17 A
AC Nominal Voltage / Range	183 - 229 V @ 208 VAC 211 - 264 V @ 240 VAC	183 - 229 V @ 208 VAC 211 - 264 V @ 240 VAC
AC Frequency / Range	60 Hz / 59.3 Hz - 60.5 Hz	60 Hz / 59.3 Hz - 60.5 Hz
Power Factor	1	1
Efficiency		
Peak Inverter Efficiency	96.6 %	96.8 %
CEC weighted Efficiency	95.0 % (@ 208 V) 95.5 % (@ 240 V)	95.5 % (@ 208 V) 96.0 % (@ 240 V)
Mechanical Data		
Dimensions W x H x D in inches	17.8 x 13.8 x 9.3	17.8 x 13.8 x 9.3
Weight / Shipping Weight	88 lbs / 94 lbs	88 lbs / 94 lbs
Ambient temperature range	-13 to +113 °F	-13 to +113 °F
Power Consumption: standby / nighttime	< 7 W / 0.1 W	< 7 W / 0.1 W
Topology	PWM, true sinewave, current source	PWM, true sinewave, current source
Cooling Concept	Convection, regulated fan cooling	Convection, regulated fan cooling
Mounting Location Indoor / Outdoor (NEMA 3R)	● / ●	● / ●
Features		
LCD Display	●	●
Lid Color: aluminium / red / blue / yellow	● / ○ / ○ / ○	● / ○ / ○ / ○
Communication: RS485 / Wireless	○ / ○	○ / ○
Warranty: 5-year / 10-year	● / ○	● / ○
Compliance: IEEE-929, IEEE-1547, UL 1741, UL 1998, FCC Part 15 A & B	●	●
Specifications for nominal conditions	● Included ○ Option – Not available	

Efficiency Curves

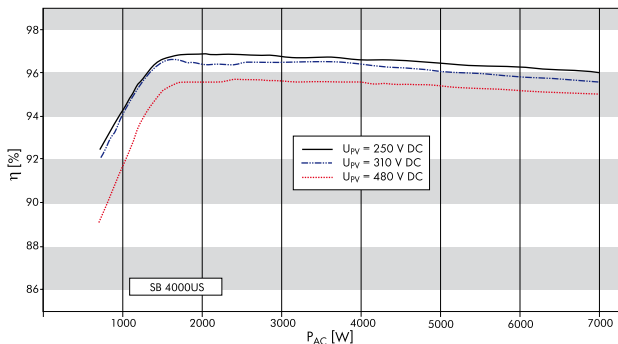

Array 1
 18 - Kyocera 167G Modles
 System Wattage 3,006 DC Watts x 0.77 = 2,315 AC Watts
 Operating Current 7.20 Amps DC
 Operating Voltage 371.2 Volts DC
 Max. System Voltage 462.4 Volts DC
 Short Circuit Current 8.00 Amps

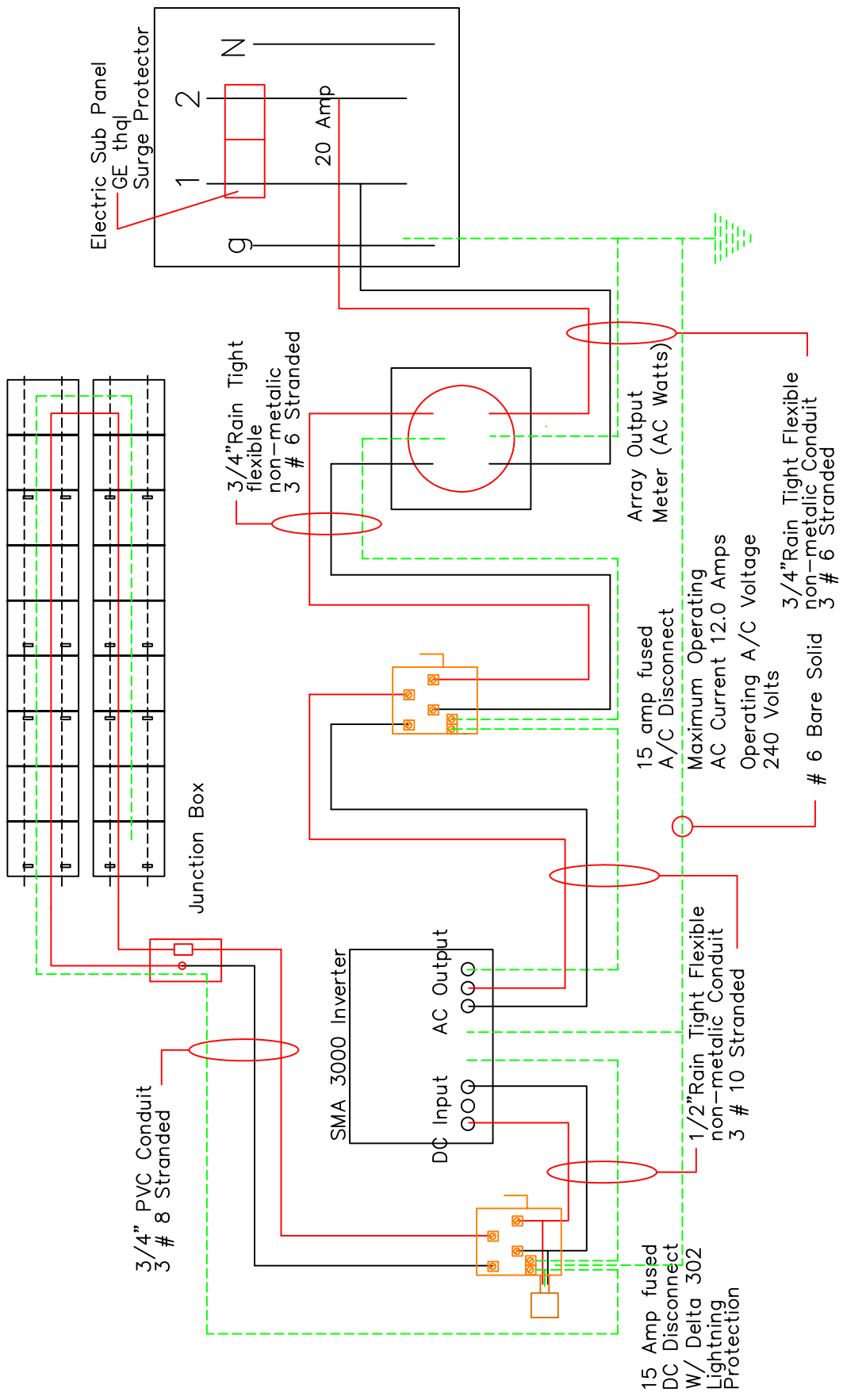



1703 W. Koenig Lane

Austin, TX 78756

Phone:(512) 459-9494 Fax:(512) 451-5934 Email:Info@txspc.com

WARRANTIES

Solar Panels

25 Year Prorated Warranty

Charge Controller

2 Year Limited Warranty

Inverter

10 Year Limited Warranty

Batteries

As per Manufacturer

Installation

5 Year Unlimited Labor and Material

Texas Solar Power Company will extend all manufacturer warranties for a period of five years from the date of system acceptance by Austin Energy.

(Excluding Batteries and Charge controllers)

If for any reason any equipment fails during this five year period Texas Solar Power Company will replace or repair at no cost to the Austin Energy Customer. This warranty is transferable in the event of sale of home or office.

EMERGENCY PHONE NUMBERS

Office Address: 1703 West Koenig Lane
Austin, Texas 78756

Office Hours

Monday through Friday 9:00 a.m. to 6:00 p.m.

Office Phone: 512-459-9494

Fax: 512-451-5934

Toll Free: 866-459-9494

Craig Overmiller

Residence: 512-477-9996

Cell Phone: 512-632-3237

Email: craig@txspc.com

Joe Garcia

Residence: 512-282-9085

Cell Phone: 512-789-3477

Email: joe@txspc.com

TEXAS SOLAR POWER COMPANY



This is an example of a 3kw system consisting of 18 panels @ 175 watt each.

This is an example of the components used to tie into your standard power grid. These will be added (l to r):

1. DC Disconnect
2. Inverter
3. AC Disconnect
4. PV Meter

These are pre-existing on your home:

5. Breaker Box, or Load Center
6. Revenue Meter



References

Commercial Clients:

Iron Knot Retreat Center

Michael Bradfute

Phone: 505-301-3388

21,100 Watts PV

4 Outback 3648 Inverters

64 DeKa Solar 8A8D Batteries

Community Clinical Research

Sam Dawson

Phone: 512-868-1229

20,000 Watts PV

4 Fronius 5100 IG Inverters

2 Outback 3648 Inverters

16 Trojan 8A8D Batteries

Alori Properties

Jason Aldridge

409 West 38th Street

Phone: 512-452-3690

25,000 Watts

5 Fronius 5100 IG Inverters

Ebby Construction

George Ebby

Austin, Texas

Phone: 263-0805

16,000-Watts Solar

6 Trace 5548 Inverters

24 MK 8A31 AGM Batteries Batteries

Texas A&M University

Forrest McCartney

Phone: 979-845-5318

4000 Watts PV

1-Xantrex GT 3.0 Inverter

1-Xantrex 2024 Inverter

1-Southwest Wind Air 403 Wind Generator

1-Southwestwind H80 Wind Generator

Read Trust

Patsy Read

Phone: 477-9996

3000 Watts PV

1-Xantrex 4048 Inverter

2-Southwestwind Air 403 Wind Generator

8-Deka Solar 8G27 Gel Cell Batteries

Sportsman's Finest

Charles Dorrance

12434 FM 2244

Bee Caves, TX

Phone: 263-1888

14KW Grid-tie System

(2) SMA 6000 Watt Inverters

City Of Austin Projects

Wild Basin Preserve

David Burgos

Phone: 482-5368

8,000 Watts PV

2-Omnion 5 KW Inverters

Metz Recreation Center

David Burgos

Phone: 482-5368

3000 Watts PV

1-3000 Watt SMA Inverter

Seawright Park

David Burgos

Phone: 482-5368

900 Watts PV

1-Xantrex 1500 Watt Inverter

8-Deka Solar 8A31 AGM Batteris

Austin Independent School District

David Burgos

Phone: 482-5368

15,600 Watts

5 Fronius IG 44500 Inverters

City of Austin Rebate Customers:

David Murphy
davidmurphy02@yahoo.com
9015 Spicebrush Dr.
418-1706
3,150-Watt PV System
SMA Inverter and Solar World modules

Dan Mackay
dmackay@austin.rr.com
609 Furlong Dr.
327-5632
6,300-Watt PV System
(2) SMA Inverters and Solar World modules

Consuelo Allen
consuelo@austin.rr.com
5305 Agatha Circle
3,150-Watt PV System
Fronius Inverter and Kyocera modules

Jim and Lynn Weber
webers@austin.rr.com
6808 Jester Wild Drive
3,150-Watt PV System
SMA Inverter and Solar World modules

Ron Craw
rcraw@austin.rr.com
7108 Kenosha Pass
3,150-Watt PV System
Fronius Inverter and Kyocera modules

(from http://www.btutilities.com/New_Ventures/Rebates/Solar/ProgramGuidelines.aspx)

BTU's Green Plus Solar PV Customer Photovoltaics

Program Guidelines

Why Participate In The Program?

BTU's Solar Rebate Program is designed to help you implement photovoltaic (PV) technology in your home or business by offering financial incentives that can offset your initial investment. By using BTU as your energy management partner, we can offer unbiased expertise to help you decide how to make the most effective use of your energy dollars. By implementing PV technology, you will be helping BTU reduce the need to generate additional power, lower our long-term investment costs for new electric facilities and also enhance our City's environment.

General Qualifications and Guidelines

Installation and Warranties

- All work must be performed in accordance with all applicable federal, state, and local, manufacturer's codes and standards as well as BTU Interconnection Guidelines.
- Rebate applicants must use a BTU registered installer. A list of registered installers will be found on BTU's website. Installers must be certified by NABCEP (North American Board of Certified Energy Practitioners) within two years of becoming registered with BTU. For details on how to become NABCEP certified, please visit their website.
- Only eligible PV modules qualify for rebates under the BTU program. A list of eligible PV modules and eligible list of inverters is found on the CEC website:

<http://www.gosolarcalifornia.org/equipment/index.html>

NOTE: BTU is not a manufacturer, supplier or guarantor of the PV system or installers, and BTU, whether by making available a list of registered installers and equipment sources or otherwise, has not made and makes no representations or warranties of any nature, directly or indirectly, express or implied, as to performance of the installer or reliability, performance, durability, condition or quality of the PV system selected and purchased.

- All PV systems installed must carry a 5-year warranty from the installer in addition to a 10-year manufacturer warranty on inverters in residential applications without battery back-up.
- Licensed electrical contractors must obtain appropriate permits and perform all electrical interconnections.
- All inverters and solar modules must be new.
- PV system installations on flat roof residential structures and all commercial buildings must also obtain appropriate City of Bryan building permits.
- All PV systems must be interconnected, at customer's expense, to BTU's electrical grid. The PV system will comply with current BTU guidelines governing interconnection with BTU electric system, and any subsequent revisions to these guidelines.
- If re-roofing is required, PV system removal and reinstallation is at customer expense.
- Batteries are not covered under the rebate.

Rebate Funding

- Rebate funding is offered on a first-come, first-served basis.
- Participation in the Solar Rebate Program does not affect customer participation in other BTU conservation programs.

- BTU will perform a pre-inspection of the site; results of the pre-inspection will determine rebate eligibility. Solar Pathfinder plot must demonstrate minimal shading by trees, buildings and other structures. BTU retains the right to deny rebates based on excessive shading and or poor orientation of the solar array.
- The requested rebate amount will be calculated as:
[Number of PV Modules] x [STC Rating per Module (Watts)] x [Inverter Efficiency] x [\$4.00/W]
- The standard rebate level for qualifying equipment is \$4.00 per Watt. *IRS designated Non-Profits are also eligible for the \$4.00 per watt rebate level.*
- The final rebate level will be determined following verification of the installed system by BTU solar field inspector.
- The maximum rebate per customer is capped at 80% of invoice cost or \$12,000 “per fiscal year” (October – September) for each customer site.
- Customers have the option to assign the rebate directly to the PV system installer/supplier or other third party.
- In custom homes, the rebate check goes to the builder, unless the customer can prove that he or she specified the equipment, in which case the check would go to the customer.
- New construction rebate checks can be issued before the Certificate of Occupancy is released.
- Individual condominium owners applying must obtain Condo Association permission.
- Condo Associations must be connected to a commercial meter.
- Apartments qualify and must be under a single rebate application.

Additional Requirements

- Deed restrictions must not prohibit the installation of solar photovoltaics on property.
- The customer must transfer to BTU, all renewable energy credits (RECs) and other environmental attributes from power generated by PV systems receiving rebates from BTU. RECs may be retained if the proper documents are submitted proving that the RECs are required to achieve LEED certification. (See BTU Renewable Energy Credit Agreement).
- Customer must have an active BTU electric account number.
- Customers currently participating in the self-read meter program must provide BTU access to the new solar and revenue meters.
- PV system cannot be removed from BTU service territory.
- Customer must sign the rebate refund agreement on the Solar Rebate Application form.
- BTU guidelines and rebate levels are subject to change without notice, and BTU reserves the right to refuse any application/request for incentive payment that does not meet BTU's requirements.

Refund Agreement

- A refund shall become due and payable to BTU if the customer fails to ensure BTU that the rebated equipment is properly maintained and operated at an BTU metered address.
- The refund will be calculated by reducing the rebate paid by 20% per year for each of the five years following final inspection and approval (first 20% reduction to occur on the anniversary date of rebate payment).



Renewable Energy Rebate SOLAR PV PROGRAM APPLICATION



For Office Use Only:
Ref. # _____

Purchaser

Name _____ Installation Address _____ Zip _____

Mailing Address (if different) _____ Zip _____

Electric Account # _____ Email Address _____

Day Phone # (____) _____ Wk. Phone # _____

Contractor/Installer

Name and Registration # _____

Contact Person _____ Email Address _____

Installer's Address _____ Ph. Number (____) _____

City, State & Zip Code _____ Fax Number (____) _____

System/Installation

Residential Commercial Multi-Family	Structure: New Existing	Contractor Price Quote: \$ _____	Est. kWh Savings/yr.: _____	Methodology Used: _____
---	-------------------------------	-------------------------------------	--------------------------------	----------------------------

PV Module Mfg.* _____ Model # _____ Qty. _____ STC Rating (watts) _____ Array Orientation _____	Inverter Mfg.* _____ Model # _____ Power Rating _____ Efficiency % _____
---	--

**Please list additional modules/inverters on reverse side of this application.*

Number of Modules	x	STC Rating (watts)	x	Inverter Eff. %	=	System Rating (W)	x	Rebate Level	=	Rebate Amount
_____	x	_____	x	_____	=	_____	x	\$ _____	=	\$ _____
_____	x	_____	x	_____	=	_____	x	\$ _____	=	\$ _____

BTU Site Survey Completed Yes No Application Review Date _____ Approved _____ Disapproved _____

I certify that the above listed solar PV equipment meets the program guidelines and requirements of the Solar PV Rebate Program and that all documentation submitted is true and correct to the best of my knowledge. I further certify that the photovoltaic system will be installed in compliance with BTU's technical requirements for distributed generation interconnection (for facilities under 20 kW).

Vendor/Contractor's Signature _____ Date _____

REFUND AGREEMENT

As a qualified BTU customer and purchaser of the solar system, I understand the rebate for which I am applying will, under no circumstances, exceed the maximum allowed under current Solar PV Rebate Program guidelines. In order to receive the rebate, I understand that the solar system must be inspected and approved by BTU, and I must sign this Refund Agreement that includes, at a minimum, the following conditions. A prorated portion of the rebate, calculated by reducing the rebate paid by 20% per year for each of the five years following final inspection and approval (first 20% reduction to occur on the first anniversary date of rebate payment), shall become due and payable to BTU if I fail to ensure BTU that the rebate equipment is properly maintained and operated at a BTU metered address.

Purchaser's Signature _____ Date _____

Please submit by fax to: (979) 821-5775 or mail to:
Solar PV Rebate Program
205 E. 28th St
Bryan, TX 77803

Rebate Calculations for Additional Equipment

Number of Modules	x	STC Rating (watts)	x	Inverter Eff. %	x	Rebate Level*	=	Rebate Amt.
_____	x	_____	x	_____	x	_____	=	\$ _____
_____	x	_____	x	_____	x	_____	=	\$ _____
_____	x	_____	x	_____	x	_____	=	\$ _____

*Standard rebate is amount allowed under current Solar (PV) Program Guidelines.

- All equipment (modules, inverters), as submitted on this application must be listed as eligible equipment under the California Energy Commission’s (CEC) Emerging Renewables Program.
- Eligible photovoltaic module list can be found on CEC’s website at:
http://www.gosolarcalifornia.ca.gov/nshp/eligible_pv.html
- Also, the inverter eligibility list can be found at: http://www.consumerenergycenter.org/cgi-bin/eligible_inverters.cgi
- The photovoltaic system must be installed in compliance with BTU’s technical requirements for distributed generation interconnection (for facilities under 20 kW).
- In addition to equipment eligibility requirements, solar contractors participating in the Solar Rebate Program must be certified (within two years of BTU Solar Rebate Program registration) through the North American Board of Certified Energy Practitioners (NABCEP). For details on how to become NABCEP certified, please visit their website at:
<http://www.nabcep.org/nabcep/www/pages/home/index.asp>.
- The standard rebate level for qualifying equipment shall not exceed the maximum allowed under current Solar PV Rebate Program Guidelines.

Texas Solar Power Company recommends that you consult with your tax professional before investing in solar energy to determine how incentives relate to you.

Residential Solar Tax Credit – Overview*

<i>Incentive Type:</i>	Personal Tax Credit
<i>Eligible Technologies include:</i>	Solar Water Heat, Solar Photovoltaics (i.e. electricity production)
<i>Applicable Sectors:</i>	Residential
<i>Amount:</i>	30%
<i>Maximum Incentive:</i>	No maximum for solar-electric systems or solar water-heating systems
<i>Carryover Provisions:</i>	Excess credit may be carried forward to succeeding tax year.
<i>Eligible System Size:</i>	Not specified
<i>Equipment/Installation Requirements:</i>	Solar water heating property must be certified by SRCC or by comparable entity endorsed by the state in which the system is installed. At least half the energy used to heat the dwelling's water must be from solar in order for the solar water-heating property expenditures to be eligible.
<i>Authority 1:</i>	26 USC § 25D
<i>Date Enacted:</i>	8/8/2005
<i>Effective Date:</i>	1/1/2006
<i>Expiration Date:</i>	12/31/2008

NOTE: Key points of the Energy Policy Act (passed October, 2008) and stimulus package (passed February, 2009):

- Eight-year extension of the credit to December 31, 2016
- Credit can be used against the alternative minimum tax
- If the federal tax credit exceeds tax liability, the excess amount may be carried forward to the succeeding taxable year.
- **30% of qualified expenditures for a system. There is no cap.**
 - System must serve a dwelling unit, located in the US, used as a residence.
 - Expenditures include labor costs for onsite preparation, assembly, or original system installation and for piping or wiring to interconnect a system to the home.
 - The stimulus package appears to allow the tax credit to be taken before any rebates are factored in. This dramatically affects the bottom line in areas where rebates are affected.
 - If the taxpayer cannot use the tax credit, it appears that it can be taken as a cash rebate.

The maximum allowable credit, equipment requirements, and other details vary by technology as outlined below.

Solar electric property

- Maximum credit of \$2,000 for systems placed in service from January 1, 2006 through December 31, 2008.
- No maximum credit limit for systems placed in service from January 1, 2009 through December 31, 2016.
- The home served by the system does not have to be the taxpayer's principal residence.

Solar water heating property

- Maximum credit of \$2,000 for systems placed in service from January 1, 2006 through December 31, 2008.
- No maximum credit limit for systems placed in service from January 1, 2009 through December 31, 2016.
- Systems must be placed in service from January 1, 2006 through December 31, 2016.
- Equipment must be certified for performance by the Solar Rating Certification Corporation (SRCC) or a comparable entity endorsed by the government of the state in which the property is installed.
- At least half the energy used to heat the dwelling's water must be from solar in order for the solar water-heating property expenditures to be eligible.
- The tax credit does not apply to solar water heating property for swimming pools or hot tubs.
- The home served by the system does not have to be the taxpayer's principal residence.

Background

The [Energy Policy Act of 2005](#) (Section 1335) established a 30% tax credit up to \$2,000 for the purchase and installation of residential solar electric and solar water heating property and a 30% tax credit up to \$500 per 0.5 kilowatt for fuels cells. Initially scheduled to expire at the end of 2007, the tax credits were extended through December 31, 2008 by Section 206 of the [Tax Relief and Health Care Act of 2006](#).

In October 2008, through the [Energy Improvement and Extension Act of 2008](#) (Division B, Section 106), the tax credits were extended once again – until December 31, 2016 – and a new tax credit for small wind energy systems and geothermal heat pump systems was created. In February of 2009 the maximum tax credit was lifted for solar hot water and the structure of the tax credit was revised.

For more information about the renewable energy component of this tax credit (including the types and use of eligible property, the credit's interaction with other incentives, and project ownership requirements), see the EnergyStar's website:

http://www.energystar.gov/index.cfm?c=products.pr_tax_credits

Or check the Database of State Incentives for Renewable Energy (DSIRE) website:

http://www.dsireusa.org/library/includes/incentive2.cfm?Incentive_Code=US37F&State=federal¤tpageid=1&ee=1&re=1

* This is an edited version by Texas Solar Power Company. Please check the link above and with your personal tax accountant to see how these credits might affect you.