

TEXAS SOLAR POWER COMPANY

1703 West Koenig Lane, Austin, Texas 78756
 Phone: (512) 459-9494 Fax: (512) 451-5934
 Toll Free: (866) 459-9494
 Web: txspc.com
 Email: info@txspc.com

Texas Solar Power Company (TXSPC) specializes in the design and installation of renewable energy systems. We provide an alternative, sustainable power source for residential, commercial and government clients. TXSPC offers outstanding service using high quality products delivered at competitive prices.



Photovoltaic (PV) is clean energy from the fuel source that belongs to all of us - the sun.



We carry everything you need for your renewable energy project. TXSPC is an authorized dealer of SolarWorld, Sharp Solar, and Kyocera modules as well as SMA and Fronius products. As technology in the renewable energy industry is dynamic, we are constantly evaluating new products and manufacturers to offer the best package to the environmentally and energy conscious public.



Our services are available around the world—wherever there is a need for photovoltaics.



Sales • Design • Installation

Owners Craig Overmiller, Architect, and Joe Garcia have been in the renewable energy field since 1995 helping home and business owners towards energy independence. The TXSPC team of designers and installers are committed to professional presentation and quality work.

Residential • Commercial

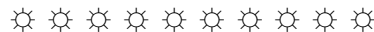

Texas Solar Power Company headquarters is a working example of integrating both a wind turbine as well as a hybrid grid-tie solar system.

- The 1st floor is an SMA Sunny Island grid-tie system with back-up batteries.
- The 3rd floor is an Outback stand-alone system.
- We also have two Air 403 wind generators on the roof for additional power.



Owner is
NABCEP Certified



At Texas Solar Power Company, YOU have the POWER.

SYSTEM SIZING 101

Before you begin to size a system for your existing home, Texas Solar Power Company recommends that you implement several energy management techniques:

- Change all incandescent and halogen light sources to compact fluorescent lighting. Home Depot is a great source for these indoor or outdoor lamps and fixtures. Most compact fluorescent lamps will fit into existing lamp sockets.
- Add additional insulation to your attic walls and floors where possible. Use pipe insulation on heated water pipes.
- Add shading devices and/or solar screens to your east, south, and west-facing windows. The south-facing screens you may want to take off in the winter for solar heat gain.
- Purchase only Energy Star rated appliances and air conditioning equipment.
- Use natural gas or propane appliances where possible for cooking, central heating, water heating, and your clothes dryer.

Determine your power needs:

If your system is tied to the grid, simply look at your electric bill to find the number of Kilowatt-hours (kWh) you use in a month. Remember that your summer bills may be higher than winter, or vice versa. Multiply your kWh by 1000 to get watts. Divide by 30.5 days per month, and then divide by 6 (or however many hours of good sunlight you expect your site to receive). Finally divide that number by the output of the solar module you intend to use (i.e. 175 watts) and your result is the number of modules you will need.

If your home is not connected to the utility grid, add up the amperage of all your anticipated electrical loads. Multiply this amperage by 120 (your AC voltage) to get your maximum wattage. Then divide by 4 to give you a rough idea of your hourly power needs.

Sizing a minimum battery bank:

Having a battery backup is essential if you're off the grid, but it can be a valuable accessory for your grid-tied home or business too. There are three important rules of electricity to remember for this discussion:

- Current is measured in amps, potential energy is measured in volts, and power is measured in watts. We find wattage by multiplying amps and volts. We can also find current by dividing watts by volts, and volts by dividing power by current.
- In order to add voltage, we connect batteries in *series* (negative to positive to negative, and so on). If we want a 48 volt system, we would connect four 12-volt batteries in series, or eight 6-volt batteries, for example. The amperage is not additive in series.
- In order to build current, we connect batteries in *parallel* (positive to positive, and negative to negative). If we want 200 amps per hour and we're using a 50 amp/hour battery, we need four rows of these batteries, connected in parallel. Voltage is not additive in parallel.

To determine how many batteries you would need, first calculate your average hourly watt needs, and divide by 120 volts AC to find amperage per hour. The minimum battery bank for off-grid use is typically designed for fourteen hours – the time from sundown to sunup. If you're on the utility grid, you need enough reserve to last through a power failure – usually four hours at most.

Your system can be 12, 24, or 48 volts DC. Of these, 48 volt is most common because of its greater efficiency. The type of system determines the multiple you will now find your DC amp/hour requirement. This multiple is 10 for a 12-volt system, 5 for 24-volt, and 2.5 for 48. So, multiply your amps per hour from the last paragraph (let's assume 10 amps/hour) by the multiple for your system (assume 48-volt) to get your DC amp/hours (25).

Select the deep-cycle battery you will be using and determine the reserve amps for that battery. Multiply your amps per hour (from above) by 14 hours. This gives your battery reserve amp required. Divide that by battery manufacturer reserve amps, and you will know how many rows of batteries in parallel you need.

The number of batteries in series in each row is determined by the battery voltage. Batteries are most commonly 6 or 12 volts. Divide the system voltage (12, 24, or 48) by the voltage of your batteries (6 or 12). This gives you the number of batteries per row.

Finally, multiply the number of batteries per row by the number of rows to find the total number of batteries.

EXAMPLE:

Let's say we're building an off-grid system. Our monthly energy requirement is 576.45 kWh.

$576.45 \text{ kWh} \times 1000 = 576,450 \text{ watts per month}$

$576,450 / 30.5 = 18,900 \text{ watts per day}$

$18,900 \text{ Watts} / 6 \text{ hours sunlight} = 3150 \text{ watts per hour (minimum)}$

Solar Modules:

Assume we're using a 175 watt 12 volt module:

$3150 / 175 = 18 \text{ modules}$

A 12 volt system would require all 8 modules to be wired in parallel

A 24 volt system requires 9 arrays, 2 panels each

48 volt is 5 arrays, 4 panels each (20 Modules are required; must be divisible by 4)

Batteries:

$18,900 \text{ watts per day} / 120 \text{ volts AC} = 158 \text{ amps per day}$

$158 \text{ amps} / 24 \text{ hours} = 6.58 \text{ amps per hour}$

Assume a 48 volt DC system, and a 12 volt 105 amp hour battery

$6.58 \text{ amps DC} \times 2.5 \text{ (48 volt multiplier)} = 16.46 \text{ amps}$

$16.48 \text{ amps} \times 14 \text{ hours} = 230.42 \text{ amps}$

$230.42 \text{ amps} / 105 \text{ amps} = 2.2 \text{ battery rows (Round up to 3)}$

$48 \text{ volt DC system} / 12 \text{ volt battery} = 4 \text{ batteries per row}$

$3 \text{ rows} \times 4 \text{ batteries} = 12 \text{ batteries total}$

ELECTRICAL SPECIFICATIONS FOR PV SYSTEM (DC AT STANDARD TEST CONDITIONS)

	NO. OF MODULES	V _{OC}	I _{SC}	V _{MP}	I _{MP}	MAX POWER (W DC)
PV MODULE KC-175	1	292	8.09	23.6	7.42	175
STRING	4 MODULES IN SERIES	1168	8.09	94.4	7.42	700
ARRAY	5 STRINGS IN PARALLEL	1168	40.45	94.4	371	3500

- NOTES:
- SYSTEM - BATTERY BACK-UP/GRID-TIE MAJOR SYSTEMS COMPONENTS ARE ALL OUTBACK POWERS SYSTEMS PRODUCTS
 - 1 X MM60 CHARGE CONTROLLER
 - 2 X GVFX 3648 INVERTER (20 V 30 AMP CONTINUOUS OUTPUT)
 - ALL ENCLOSURES & COMPONENTS WILL BE INSTALLED PER OUTBACK POWER SYSTEMS SPECIFICATIONS
 - ALL EQUIPMENT TO BE INSTALLED PER MANUFACTURE SPECIFICATIONS

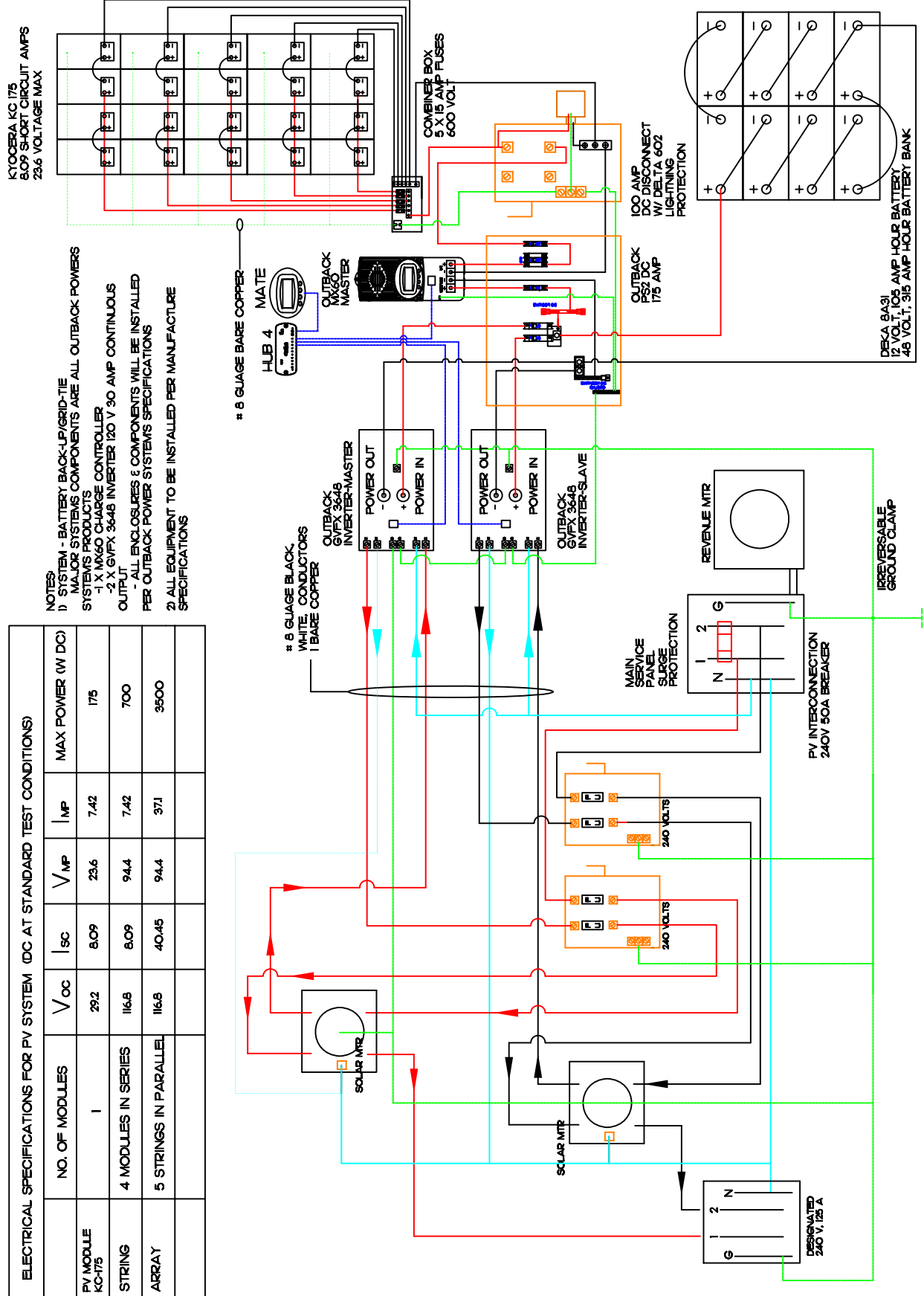

The FLEXware System

FLEXware is the latest example of OutBack's continuous efforts to bring you the most value packed and technologically advanced products available.

Our integrating partners, dealers, installers, and system owners spoke—and we listened. The resulting FLEXware is the most integrated, modular, and spacious installation system OutBack has ever designed. Its components are more versatile, the wiring space is larger, and the all-aluminum, powder-coated construction not only resists corrosion longer, but is lighter and easier to handle than our previous steel construction. OutBack's new FLEXware makes for a great looking installation that will continue to look great for years.

Designed to work as a modular “building block” architecture, FLEXware offers more versatility than ever before. From single inverter back-up systems to a multiple inverter village power system, FLEXware is the solution.

The FLEXware 250 offers the lowest cost solution for single inverter/charger installations when space and budget are primary concerns.

The FLEXware 500 supports up to two inverter/chargers and two charge controllers in an attractive, versatile and code-compliant package when more power is needed.

The FLEXware 1000 accommodates up to four inverter/chargers and four charge controllers. It can also be used for large systems with multiple power panels for systems up to 36 kW.

Both the FLEXware 500 and FLEXware 1000 systems provide ample locations for additional breakers, DC current shunts, an auto-transformer and other components required in higher kW systems.

The new FLEXware MP (mounting plate) shows the versatility of the FLEXware system with its compatibility with both the FLEXware 500 and FLEXware 1000 systems.

All of the FLEXware options have also been simplified, making the design, ordering and installation of power systems easier than ever.



 FLEXware™





32 JOBMASTER CHEST

KNAACK

THE NEW VALUE FRONTIER



KC175GT

HIGH EFFICIENCY
MULTICRYSTAL
PHOTOVOLTAIC
MODULE

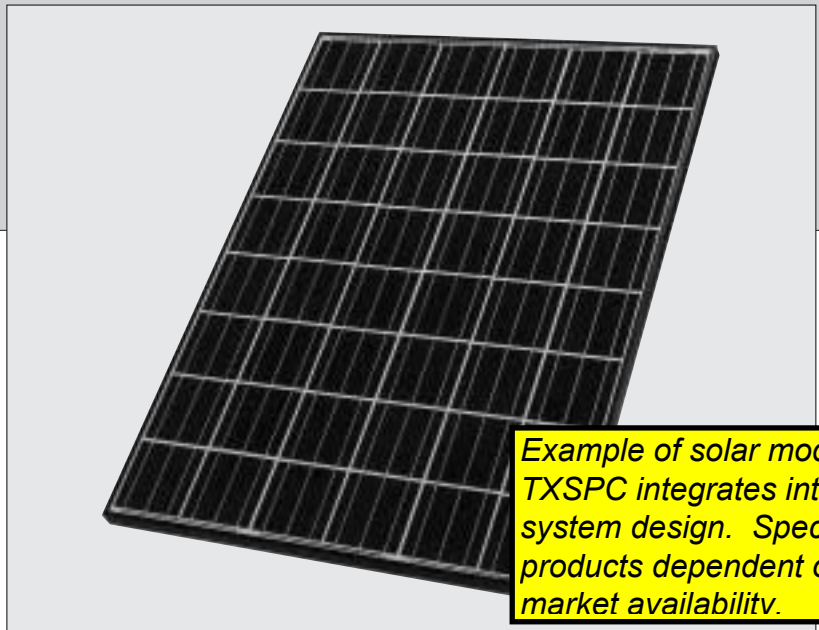

Example of solar module TXSPC integrates into PV system design. Specific products dependent on market availability.

HIGHLIGHTS OF KYOCERA PHOTOVOLTAIC MODULES

Kyocera's advanced cell processing technology and automated production facilities produce a highly efficient multicrystal photovoltaic module.

The conversion efficiency of the Kyocera solar cell is over 16%.

These cells are encapsulated between a tempered glass cover and a pottant with PVF back sheet to provide efficient protection from the severest environmental conditions.

The entire laminate is installed in an anodized aluminum frame to provide structural strength and ease of installation. Equipped with plug-in connectors.

APPLICATIONS

KC175GT is ideal for grid tie system applications.

- Residential roof top systems
- Large commercial grid tie systems
- Water Pumping systems
- High Voltage stand alone systems

QUALIFICATIONS

■ **MODULE**
UL1703 certified

■ **FACTORY**
ISO9001 and ISO14001

PERFORMANCE WARRANTY

1 year limited warranty on material and workmanship

25 year* limited warranty on power output

SPECIFICATIONS

■ Electrical Specifications

MODEL	KC175GT
Maximum Power	175Watts
Tolerance	+10% / -5%
Maximum Power Voltage	23.6Volts
Maximum Power Current	7.42Amps
Open Circuit Voltage	29.2Volts
Short-Circuit Current	8.09Amps
Length	1290mm (50.8in.)
Width	990mm (39.0in.)
Depth	36mm (1.4in.)
Weight	16.0kg (35.3lbs.)

■ Thermal parameters

Nominal Operating Cell Temperature	47°C
Isc Current temperature coefficient	(3.18×10^{-3}) A/°C
Voc Voltage temperature coefficient	(-1.09×10^{-1}) V/°C

Note: The electrical specifications are under test conditions of Irradiance of 1kw/m^2 , Spectrum of 1.5 air mass and cell temperature of 25°C

Kyocera reserves the right to modify these specifications without notice.

■ Physical Specifications

(Unit: mm)

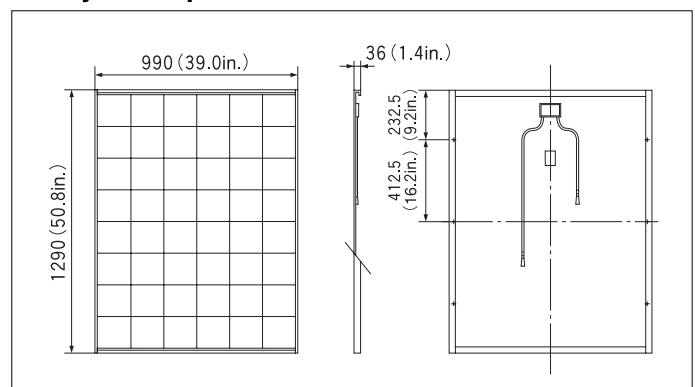

*(Long term output warranty shall guarantee that loss of output is not more than 10% of the minimum warranty value of the product specifications within 12 years and is not more than 20% within 25 years after the purchase of the product by customer. The output values shall be those measured under Kyocera standard measurement conditions. Regarding the warranty conditions in detail, please refer to Warranty issued by Kyocera.)

ELECTRICAL CHARACTERISTICS

Current-Voltage characteristics of Photovoltaic Module KC175GT at various cell temperatures

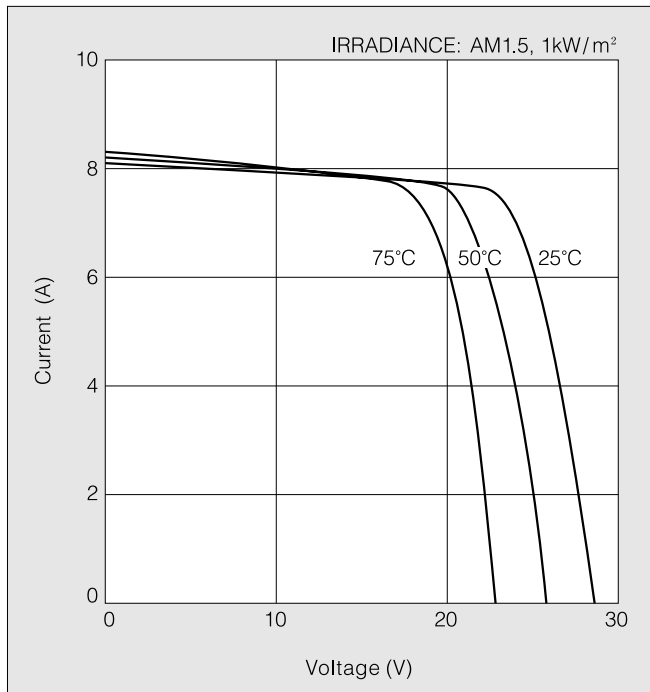

Current-Voltage characteristics of Photovoltaic Module KC175GT at various irradiance levels

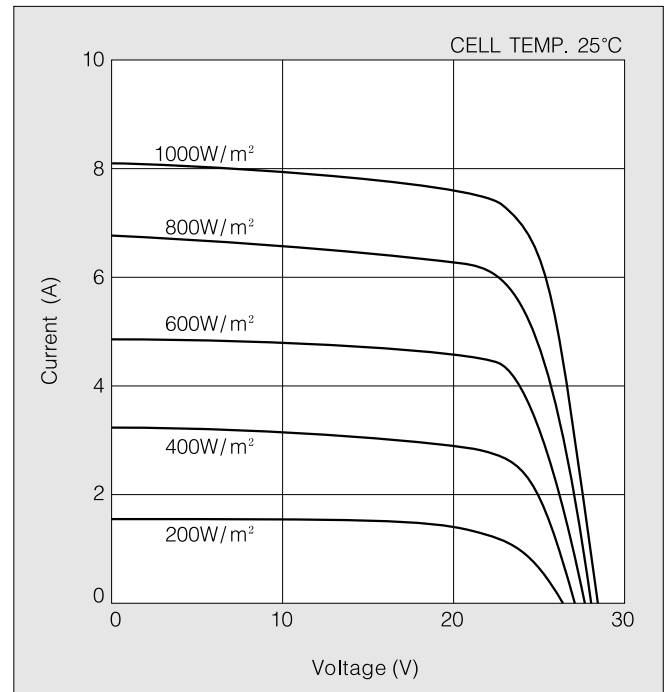

QUALITY ASSURANCE

Kyocera multicrystal photovoltaic modules have passed the following tests.

- Thermal cycling test
- Thermal shock test
- Thermal/ Freezing and high humidity cycling test
- Electrical isolation test
- Hail impact test
- Mechanical, wind and twist loading test
- Salt mist test
- Light and water-exposure test
- Field exposure test

Please contact our office to obtain details without hesitation.



KYOCERA Corporation

■ KYOCERA Head Office

CORPORATE SOLAR ENERGY DIVISION
6 Takeda Tobadono-cho
Fushimi-ku, Kyoto
612-8501 Japan
Phone:(81)75-604-3476 Telefax:(81)75-604-3475
<http://www.kyocera.com>

● KYOCERA Solar, Inc.

7812 East Acoma Drive
Scottsdale, AZ 85260
Phone:(480)948-8003 or (800)223-9580 Telefax:(480)483-6431
<http://www.kyocerasolar.com>

● KYOCERA Solar do Brasil Ltda.

Energia Renovavel LTDA,
Rua Maurisio da Costa Faria, 85
22780-280, Recreio, Rio da Janeiro, Brazil
Phone:(55)21-2437-8525 Telefax:(55)21-2437-2338
<http://www.kyocerasolar.com.br>

● KYOCERA Solar Pty Ltd.

Cnr Forbes & Riverside Drive, West End,
QLD 4101, Australia
Phone:(61)7-3844-6686 Telefax:(61)7-3844-8569
<http://www.kyocerasolar.com.au/>

● KYOCERA Fineceramics GmbH

Fritz Muller strasse 107, D-73730 Esslingen, Germany
Phone:(49)711-9393417 Telefax:(49)711-9393450
<http://www.kyocerasolar.de/>

● KYOCERA Asia Pacific Pte. Ltd.

298 Tiong Bahru Road, #13-03/05
Central Plaza, Singapore 168730
Phone:(65)271-0500 Telefax:(65)271-0600

● KYOCERA Asia Pacific Ltd.

Room 803, Tower 1 South Seas Centre, 75 Mody Road,
Tsimshatsui East, Kowloon, Hong Kong
Phone:(852)2-7237183 Telefax:(852)2-7244501

● KYOCERA Asia Pacific Ltd. Taipei Office

10 FL., No.66, Nanking West Road, Taipei, Taiwan
Phone:(886)2-2555-3609 Telefax:(886)2-2559-4131

● KYOCERA(Tianjin) Sales & Trading Corporation

Binjiang International Hotel 1106
105 Jianshe Road Heping Dist, Tianjin China
Tel:(22)2331-8590 Fax:(22)2330-6276

Example of solar module TXSPC integrates into PV system design. Specific products dependent on market availability.



Length 63.39 in (1610 mm)
Width 31.89 in (810 mm)
Height 1.34 in (34 mm)
Frame Aluminium
Weight 33 lbs (15 kg)

Sunmodule

SW 155/165/175 mono

The Sunmodule Plus heralds an innovative new module concept from SolarWorld AG. The fully automated production process at the SolarWorld factories creates a quality of module that is consistently high, which in turn will ensure high yields for the long term.

The module frame and the glass it surrounds are firmly attached to each other by silicone that is applied with continuous precision. This guarantees exceptional rigidity for the entire module and stops any possible loosening of the frame as a result of strong outward forces in cases such as sliding of heavy snow. Tests carried out in accordance with IEC 61215, applying loads up to 5.4 kN/m², confirm that the module can withstand heavy accumulations of snow and ice.

The patented, flat and compact junction box provides perfect protection against corrosion, as well as a capacity to rapidly rid itself of any excess heat providing high temperature handling. The junction box is reliably connected by a solid, welded bond to guarantee lasting functionality. In addition, high-quality, robust cables with factoryequipped connectors are used. The ability to recycle the modules and a 25-year performance warranty are the finishing touches to this top-quality concept.



Sunmodule

SW 155/165/175 mono

Performance under standard test conditions

		SW 155	SW 165	SW 175
Maximum power	P_{max}	155 Wp	165 Wp	175 Wp
Open circuit voltage	V_{oc}	43.6 V	44.0 V	44.4 V
Maximum power point voltage	V_{mpp}	34.8 V	35.3 V	35.8 V
Short circuit current	I_{sc}	4.90 A	5.10 A	5.30 A
Maximum power point current	I_{mpp}	4.46 A	4.68 A	4.89 A

Performance at 800 W/m², NOCT, AM 1.5

		SW 155	SW 165	SW 175
Maximum power	P_{max}	110.8 Wp	118.0 Wp	125.1 Wp
Open circuit voltage	V_{oc}	39.4 V	39.8 V	40.2 V
Maximum power point voltage	V_{mpp}	31.2 V	31.6 V	32.1 V
Short circuit current	I_{sc}	4.05 A	4.22 A	4.38 A
Maximum power point current	I_{mpp}	3.55 A	3.73 A	3.90 A

Minor reduction in efficiency under partial load conditions at 25°C: at 200 W/m², 95% (+/- 3%) of the STC efficiency (1000 W/m²) is achieved.

Component materials

Cells per module	72
Cell type	monocrystalline silicon
Cell dimensions	125 x 125 mm ²

System integration parameters

Maximum system voltage SC II	1,000 V _{DC}
Maximum system voltage USA NEC	600 V _{DC}
Maximum series fuse rating	15 A

Thermal characteristics

NOCT	46°C
TC I_{sc}	0.036 %/K
TC V_{oc}	-0.33 %/K

Additional data

Power tolerance	+/- 3 %
Junction box	IP 65
Connector	MC type 4

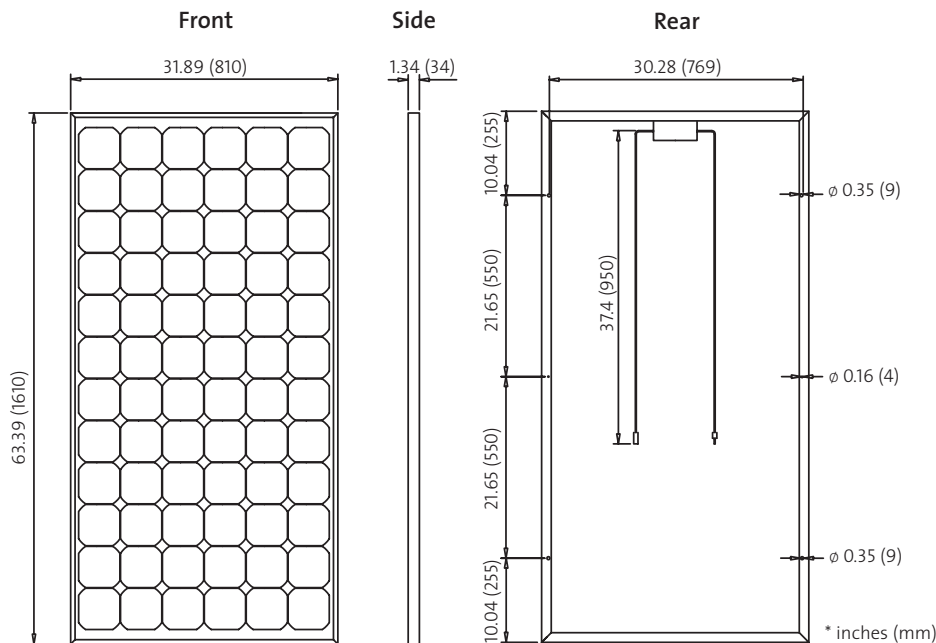

Construction

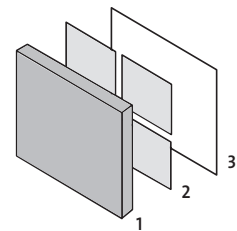

- 1] Front: tempered glass
- 2] crystalline solar cells embedded in EVA (ethylene-vinyl-acetate)
- 3] Rear: Tedlar

Modules certified in accordance with:



SolarWorld AG reserves the right to make specification changes without notice.
This data sheet complies with the requirements of EN 50380.

SunTech Power

STP 175/170/165/160S-24/Ab-1



Performance

- High power tolerance (+/- 3 %)
- 72 cell monocrystalline
- Nominal 24 V

Built for long service life

- Cells embedded in EVA (ethylene vinyl acetate)
- Transmissive low-iron, tempered glass on the front
- Weather and waterproof film back
- High strength frame

Simple installation

- Polarized Multi-Contact DC-rated waterproof connectors
- Clear anodized aluminum frame with pre-drilled holes

High quality standards

- Optical, mechanical and electrical module testing during and post-production
- Automated production line ensures consistently high level of product quality

Warranties and certifications

- 2 year product warranty
- 12 year warranty on 90 % of the minimum output
- 25 year warranty on 80 % of the minimum output
- UL 1703

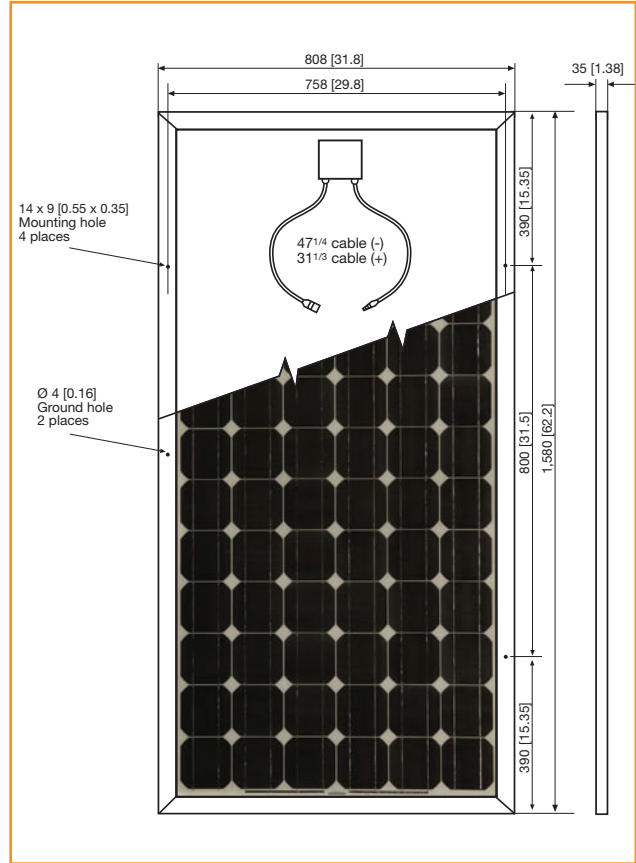

	STP 175S-24/Ab-1	STP 170S-24/Ab-1	STP 165S-24/Ab-1	STP 160S-24/Ab-1
Maximum output (Pmax)	175 W	170 W	165 W	160 W
Tolerance of the power (+/-)	3 %	3 %	3 %	3 %
Maximum power voltage (Vmp)	35.2 V	35.2 V	34.8 V	34.4 V
Maximum power current (Imp)	4.95 A	4.83 A	4.74 A	4.65 A
Open-circuit voltage (Voc)	44.2 V	43.8 V	43.6 V	43.2 V
Short-circuit current (Isc)	5.20 A	5.14 A	5.04 A	5.00 A
Temperature coefficient (Pmax)	-0.5 %/°C	-0.5 %/°C	-0.5 %/°C	-0.5 %/°C
Temperature coefficient (Voc)	-0.155 V/°C	-0.155 V/°C	-0.155 V/°C	-0.155 V/°C
Temperature coefficient (Isc)	3 mA/°C	3 mA/°C	3 mA/°C	3 mA/°C
Maximum series fuse rating	8 A	8 A	8 A	8 A
Maximum system voltage	600 V	600 V	600 V	600 V

Applies to all modules:

Module dimensions (L x W x H)	62.2 x 31.8 x 1.38 inch (1,580 x 808 x 35 mm)
Weight	34.2 lbs/15.5 kg

Available from:

8A31

SPECIFICATIONS

Nominal Voltage (V)	12V
Capacity at C/100	116.2Ah
Weight	69 (31.3 kg)
Plate Alloy	Lead Calcium
Posts	Forged terminals & bushings
Container/Cover	Polypropylene
Operating Temperature Range	-40°F (-40°C) – 140°F (60°C)
Charge Voltage @ 68°F (20°C)	
Cycle	2.40 - 2.43 VPC
Float	2.25 - 2.30 VPC
Vent	Self-sealing (2 PSI operation)
Resistance	3.0 Milliohms (full charge)
Terminal	T876

Rated non-spillable by ICAO, IATA and DOT
Approved by CEC

Made in the U.S.A by East Penn Manufacturing

Distributed by:

Valve-Regulated, Absorbed Glass Mat Technology



DIMENSIONS

Length (mm)	12.94 (329 mm)
Width (mm)	6.75 (171 mm)
Height (mm)	9.88 (251 mm)

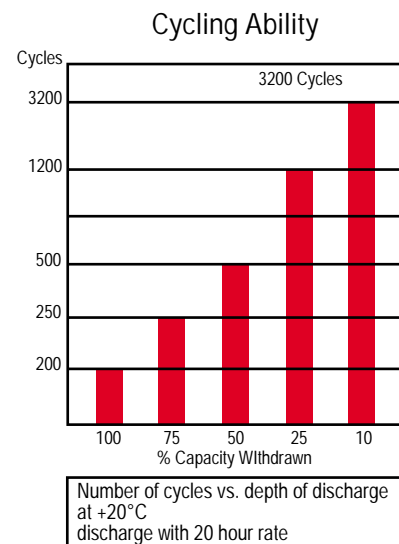

MK Battery

1645 South Sinclair Street • Anaheim, California 92806
Toll Free: 800-372-9253 • Fax: 714-937-0818 • E-Mail: sales@mkbattery.com





1703 W. Koenig Lane

Austin, TX 78756

Phone:(512) 459-9494 Fax:(512) 451-5934 Email:Info@txspc.com

WARRANTIES

Solar Panels

25 Year Prorated Warranty

Charge Controller

2 Year Limited Warranty

Inverter

10 Year Limited Warranty

Batteries

As per Manufacturer

Installation

5 Year Unlimited Labor and Material

Texas Solar Power Company will extend all manufacturer warranties for a period of five years from the date of system acceptance by Austin Energy.

(Excluding Batteries and Charge controllers)

If for any reason any equipment fails during this five year period Texas Solar Power Company will replace or repair at no cost to the Austin Energy Customer. This warranty is transferable in the event of sale of home or office.

EMERGENCY PHONE NUMBERS

Office Address: 1703 West Koenig Lane
Austin, Texas 78756

Office Hours

Monday through Friday 9:00 a.m. to 6:00 p.m.

Office Phone: 512-459-9494

Fax: 512-451-5934

Toll Free: 866-459-9494

Craig Overmiller

Residence: 512-477-9996

Cell Phone: 512-632-3237

Email: craig@txspc.com

Joe Garcia

Residence: 512-282-9085

Cell Phone: 512-789-3477

Email: joe@txspc.com

References

Commercial Clients:

Iron Knot Retreat Center

Michael Bradfute

Phone: 505-301-3388

21,100 Watts PV

4 Outback 3648 Inverters

64 DeKa Solar 8A8D Batteries

Community Clinical Research

Sam Dawson

Phone: 512-868-1229

20,000 Watts PV

4 Fronius 5100 IG Inverters

2 Outback 3648 Inverters

16 Trojan 8A8D Batteries

Alori Properties

Jason Aldridge

409 West 38th Street

Phone: 512-452-3690

25,000 Watts

5 Fronius 5100 IG Inverters

Ebby Construction

George Ebby

Austin, Texas

Phone: 263-0805

16,000-Watts Solar

6 Trace 5548 Inverters

24 MK 8A31 AGM Batteries Batteries

Texas A&M University

Forrest McCartney

Phone: 979-845-5318

4000 Watts PV

1-Xantrex GT 3.0 Inverter

1-Xantrex 2024 Inverter

1-Southwest Wind Air 403 Wind Generator

1-Southwestwind H80 Wind Generator

Read Trust

Patsy Read

Phone: 477-9996

3000 Watts PV

1-Xantrex 4048 Inverter

2-Southwestwind Air 403 Wind Generator

8-Deka Solar 8G27 Gel Cell Batteries

Sportsman's Finest

Charles Dorrance

12434 FM 2244

Bee Caves, TX

Phone: 263-1888

14KW Grid-tie System

(2) SMA 6000 Watt Inverters

City Of Austin Projects

Wild Basin Preserve

David Burgos

Phone: 482-5368

8,000 Watts PV

2-Omnion 5 KW Inverters

Metz Recreation Center

David Burgos

Phone: 482-5368

3000 Watts PV

1-3000 Watt SMA Inverter

Seawright Park

David Burgos

Phone: 482-5368

900 Watts PV

1-Xantrex 1500 Watt Inverter

8-Deka Solar 8A31 AGM Batteris

Austin Independent School District

David Burgos

Phone: 482-5368

15,600 Watts

5 Fronius IG 44500 Inverters

City of Austin Rebate Customers:

David Murphy
davidmurphy02@yahoo.com
9015 Spicebrush Dr.
418-1706
3,150-Watt PV System
SMA Inverter and Solar World modules

Dan Mackay
dmackay@austin.rr.com
609 Furlong Dr.
327-5632
6,300-Watt PV System
(2) SMA Inverters and Solar World modules

Consuelo Allen
consuelo@austin.rr.com
5305 Agatha Circle
3,150-Watt PV System
Fronius Inverter and Kyocera modules

Jim and Lynn Weber
webers@austin.rr.com
6808 Jester Wild Drive
3,150-Watt PV System
SMA Inverter and Solar World modules

Ron Craw
rcraw@austin.rr.com
7108 Kenosha Pass
3,150-Watt PV System
Fronius Inverter and Kyocera modules



SOLAR PV PROGRAM REBATE APPLICATION

Ref File.

#

Purchaser

Name _____ Installation Address _____
 Mailing Address (if different) _____
 Electric Account # _____ Email Address _____
 Day Phone # _____ Wk. Phone # _____

Contractor/Installer

Name _____
 Contact Person _____ Email Address _____
 Installer's Address _____ Ph. Number _____
 City, State & Zip Code _____ Fax Number _____

System/Installation

Residential <input type="checkbox"/>	Structure:	Contractor Price Quote:	Locally Made:	Est. kWh Savings/yr.:	Methodology Used:
Commercial <input type="checkbox"/>	New <input type="checkbox"/>	\$ _____	Yes <input type="checkbox"/> No <input type="checkbox"/>		
Multi-Family <input type="checkbox"/>	Existing <input type="checkbox"/>				

PV Module Mfg.* _____	Inverter Mfg.* _____
Model # _____ Qty. _____	Model # _____
STC Rating (watts) _____ Array Orientation _____	Power Rating Efficiency % _____

**Please list additional modules/inverters on reverse side of this application.*

Number of Modules	x	STC Rating (watts)	x	Inverter Eff. %	=	System Rating (W)	x	Rebate Level	=	Rebate Amount
Array 1:		_____		_____		_____		\$ _____		\$ _____
Array 2:		_____		_____		_____		\$ _____		\$ _____

AE Inspector _____ Application Review Date _____ Approved _____ Disapproved _____

I certify that the above listed solar PV equipment meets the program guidelines and requirements of the Solar PV Rebate Program and that all documentation submitted is true and correct to the best of my knowledge. I further certify that the photovoltaic system will be installed in compliance with Austin Energy's technical requirements for distributed generation interconnection (for facilities under 20 kW).

Vendor/Contractor's Signature _____ Date _____

REFUND AGREEMENT

As a qualified Austin Energy customer and purchaser of the solar system, I understand the rebate for which I am applying will, under no circumstances, exceed the maximum allowed under current Solar PV Rebate Program guidelines. In order to receive the rebate, I understand that the solar system must be inspected and approved by Austin Energy, and I must sign this Refund Agreement that includes, at a minimum, the following conditions. A prorated portion of the rebate, calculated by reducing the rebate paid by 20% per year for each of the five years following final inspection and approval (first 20% reduction to occur on the first anniversary date of rebate payment), shall become due and payable to Austin Energy if I fail to ensure Austin Energy that the rebate equipment is properly maintained and operated at an Austin Energy metered address.

Purchaser's Signature _____ Date _____

Please submit by fax to: (512) 482-5409 or mail to:
 Solar PV Rebate Program
 721 Barton Springs Road
 Austin, Texas 78704



Solar PV Rebate Program

Renewable Energy Credit Assignment Agreement

Ref.# _____

The City of Austin, d/b/a Austin Energy (“Austin Energy”), committed by City Council to support renewable energy, is a voluntary participant in the State’s goal to have a total, cumulative installed generating capacity in Texas from renewable energy resources of at least 5,000 megawatts by 2015.

Under the State’s renewable energy goals program, a Renewable Energy Credit (REC) represents the environmental attributes of one thousand kilowatt hours (kWh) of electricity produced by a renewable resource (such as solar or wind). A REC is a commodity awarded to the generator of each one thousand kWh of renewable energy produced in the state. RECs are used by electric providers in Texas to account for their participation in the State’s renewal energy goals program.

RECs will be generated by your solar energy system. For example, a three (3) kW residential solar system generally produces about 4,500 kWh of renewable energy annually (for an optimal installation), creating approximately 4.5 RECs. RECs have a monetary value on the open market, which fluctuates with the market. RECs can be sold on the open market and transferred. You are being asked to assign the RECs—and any other premiums approved by the Texas Public Utility Commission—generated by your solar system to Austin Energy in order to receive the solar rebate incentive. The RECs will be aggregated with those of other participants in the Solar Rebate Program, and will be used for solar energy programs, to promote the use of solar energy, and to promote Austin Energy’s renewable energy goals.

By signing the REC Assignment Agreement, you are agreeing to assign the RECs generated by your solar system to Austin Energy in consideration for receipt of a rebate.

I _____ (please print) acknowledge that I have read the above explanation and understand by signing this agreement that I agree to assign the RECs generated by my solar system at a meter within Austin Energy’s certificated area to Austin Energy in consideration for any solar rebate incentive provided to me.

Customer Signature

Company Name (if applicable)

Installation Address

Date

Summary

Established by the federal *Energy Policy Act of 2005*, the federal tax credit for residential energy property initially applied to solar-electric systems, solar water heating systems and fuel cells. *The Energy Improvement and Extension Act of 2008* (H.R. 1424) extended the tax credit to small wind-energy systems and geothermal heat pumps, effective January 1, 2008. Other key revisions included an eight-year extension of the credit to December 31, 2016, the ability to take the credit against the alternative minimum tax, and the removal of the \$2,000 credit limit for solar-electric systems beginning in 2009. The credit was further enhanced in February 2009 by *The American Recovery and Reinvestment Act of 2009*, which removed the maximum credit amount for all eligible technologies (except fuel cells) placed in service after 2008.

A taxpayer may claim a credit of 30% of qualified expenditures for a system that serves a dwelling unit located in the U.S. used as a residence by the taxpayer. Expenditures with respect to the equipment are treated as made when the installation is completed. If the installation is on a new home, the "placed in service" date is the date of occupancy by the homeowner. Expenditures include labor costs for onsite preparation, assembly, or original system installation and for piping or wiring to interconnect a system to the home. If the federal tax credit exceeds tax liability, the excess amount may be carried forward to the succeeding taxable year. The maximum allowable credit, equipment requirements, and other details vary by technology as outlined below.

Significantly, The American Recovery and Reinvestment Act of 2009 repealed a previous limitation on the use of the credit for eligible projects also supported by "subsidized energy financing." For projects placed in service after December 31, 2008, this limitation no longer applies.

Solar electric property

- **There is *no maximum credit* for systems placed in service after 2008.**
- For systems placed in service before 1/1/2009, the maximum credit is \$2,000.
- Systems must be placed in service from 1/1/2006, through 12/31/ 2016.
- The home served by the system does not have to be the taxpayer's principal residence.

Solar water heating property

- **There is *no maximum credit* for systems placed in service after 2008.**
- For systems placed in service before 1/1/2009, the maximum credit is \$2,000.
- Systems must be placed in service from 1/1/2006, through 12/21/ 2016.
- Equipment must be certified for performance by the Solar Rating Certification Corporation (SRCC) or a comparable entity endorsed by the government of the state in which the property is installed.
- At least half the energy used to heat the dwelling's water must be from solar in order for the solar water-heating property expenditures to be eligible.
- The tax credit does not apply to solar water-heating property for swimming pools or hot tubs.
- The home served by the system does not have to be the taxpayer's principal residence.

Small wind-energy property

- **There is *no maximum credit* for systems placed in service after 2008.**
- For systems placed in service in 2008, the maximum credit is \$500 per half kilowatt, not to exceed \$4,000.
- Systems must be placed in service from 1/1/2008, through 12/21/ 2016
- The home served by the system does not have to be the taxpayer's principal residence.

History

The federal [Energy Policy Act of 2005](#) established a 30% tax credit up to \$2,000 for the purchase and installation of residential solar electric and solar water heating property and a 30% tax credit up to \$500 per 0.5 kilowatt for fuel cells. Initially scheduled to expire at the end of 2007, the tax credits were extended through December 31, 2008, by the [Tax Relief and Health Care Act of 2006](#).

In October 2008, the [Energy Improvement and Extension Act of 2008](#) extended the tax credits once again (until December 31, 2016), and a new tax credit for small wind-energy systems and geothermal heat pump systems was created. In February 2009, *The American Recovery and Reinvestment Act of 2009* removed the maximum credit amount for all eligible technologies (except fuel cells) placed in service after 2008.

***This information is from the Database of State Incentives for Renewable Energy (DSIRE) website:**

http://www.dsireusa.org/library/includes/incentive2.cfm?Incentive_Code=US37F&State=federal¤tpageid=1&ee=1&re=1 This is slightly edited (for brevity) by Texas Solar Power Company. Please refer to the link and consult with your personal tax accountant to see how these credits impact your situation. On the www.dsireusa.org version, you will find hot links to the actual bills and pertinent IRS forms.